

# Clarke®



## INSTANT GARAGE

MODEL NO: CIG81220

PART NO: 3503576

## ASSEMBLY INSTRUCTIONS

---

## INTRODUCTION

---

Thank you for purchasing this CLARKE Instant Garage. When erected, the CIG81220 garage will be of the dimensions show below. The weight is 73kg packed (71 kg unpacked).

Before attempting to use this product, please read this manual thoroughly and follow the instructions carefully. In doing so you will ensure the safety of yourself and that of others around you, and you can look forward to your purchase giving you long and satisfactory service.

---

## SAFETY WARNINGS

---



**WARNING: READ THESE SAFETY INSTRUCTIONS TO REDUCE THE RISK OF INJURY. RETAIN THESE INSTRUCTIONS FOR FUTURE REFERENCE.**

---

DO NOT use this product in environments for which it is not Intended (i.e. extreme cold, high winds, extreme heat, heavy rainfall, etc).

DO NOT use open flames or cooking or heating devices inside or in close proximity to the garage including all types of stoves, gas heaters, gas lanterns, torches, fly killers, etc. The fabric will burn if left in continuous contact with a naked flame.

DO NOT store flammable liquids (petrol, kerosene, propane, etc.) in the garage or operate gas powered vehicles/equipment in or around the garage.

---

## GUARANTEE

---

This product is guaranteed against faulty manufacture for a period of 12 months from the date of purchase. Please keep your receipt which will be required as proof of purchase.

This guarantee is invalid if the product is found to have been abused or tampered with in any way, or not used for the purpose for which it was intended.

Faulty goods should be returned to their place of purchase, no product can be returned to us without prior permission.

This guarantee does not effect your statutory rights.

---

# POSITIONING AND INSTALLATION OF THE GARAGE

---

## POSITIONING THE GARAGE

This garage is a temporary structure and is not recommended as a permanent building. It is designed to offer protection from sun, rain, light snow, tree sap and bird droppings etc. It is not designed to shelter equipment from excessively high winds or heavy snow.

Choose your garage location carefully. Check for overhead power lines, tree branches, etc. DO NOT install near roofs or other structures that may shed snow, ice or excessive run-off onto your garage.

## SITING THE GARAGE

Erect your garage on level ground. The garage should be erected over a firm, level area but with enough space near each corner for the ground anchors and tie-down straps to be used as intended. If the ground area is of tarmac or concrete, the use of ground anchor holding-down bolts will be required to anchor the garage to the floor.

Choose a dry location where dampness arising from ground water in the environment will not undermine the protection offer by the garage.

Ideally, a masonry floor such as block paving or concrete is ideal, but if this is not being supplied, a timber or shuttering plywood floor, protected by a suitable groundsheet should be used. This will help to create a dry storage environment by insulating the garage storage space from ground moisture.

**Proper anchoring and keeping the cover tight and free of snow and debris is the responsibility of the user. Damage caused by improper anchoring is not covered under warranty.**

---

## CARE OF THE GARAGE STRUCTURE

---

This garage is NOT designed to support heavy snow. Snow or ice accumulation may cause your garage to collapse. To avoid overload, brush snow and ice off the roof top with a broom or mop to prevent collapse with the resultant damage to property or personal injury.

NEVER clear the roof of snow or debris from inside the garage.

DO NOT use hard-edged tools or instruments, such as rakes or shovels to remove snow. These can cause punctures to the cover.

DO NOT use bleach, alkaline or harsh detergents for cleaning. Doing so will damage the material. Soap and warm water are recommended.

In order to reduce risk of burning and avoid damage, DO NOT- cook, smoke, refuel or use any open flame devices in or around the garage.

---

## USING THE STORAGE SPACE

---

Never run the engine of any vehicle or machine inside a closed garage. Ensure that there is adequate ventilation for engines or for any work with paints, cleaners, etc. by opening the door panel and keeping it raised as shown in diagram M on page 13.

### CONDENSATION

Take steps to avoid the buildup of condensation inside the garage. Cool, damp winter days and moisture from the breath and body heat of personnel may cause condensation on the inside of the top cover of the garage.

A supply of fresh air through the doorway will at least partly remove this issue.

For long term storage of moisture sensitive belongings in all weathers, the use of a Dehumidifier may be required, such as those in the Clarke range. A suitable extension lead to a locally available power supply will be required. Condensation will be much less of an issue during the summer months.







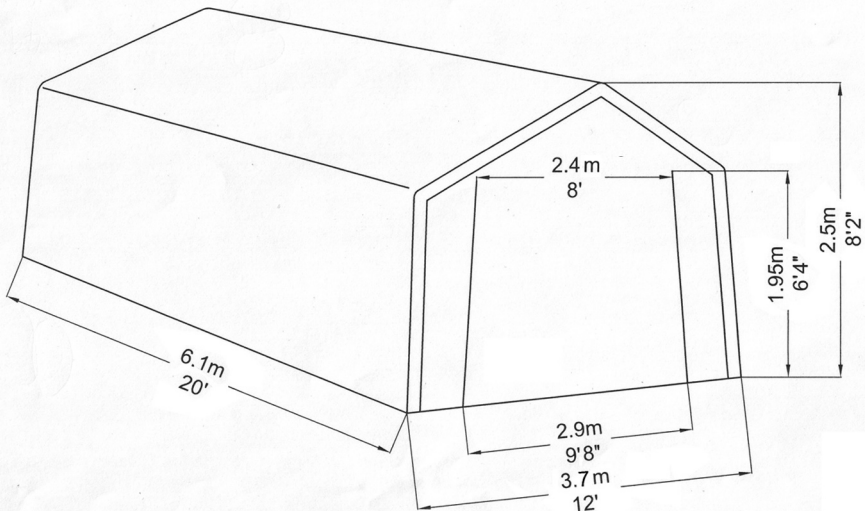



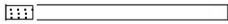

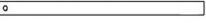











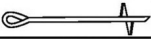
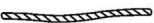

If storing a vehicle in your garage over the winter months we recommend the use of a secondary lightweight cover over your vehicle.

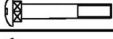
### CONSTRUCTION

Have an overview of all parts before attempting installation and make sure all components are supplied.



# COMPONENT PARTS LIST

Part	Description	Image	Qty
1	Leg Tube (top part)		12
2	Centre extension leg tube		8
3	Leg Tube (lower corner)		4
4	Rafter Tube 1		12
5	Rafter Tube 2		12
6	Apex and Shoulder Tube		15
7	Bottom Cover Rail		10
8	3-Way Side Connector-left		2
9	3-Way Side Connector-right		2
10	Bent Corner Leg		4
11	4-Way Connector		8
12	3-Way Apex Connector		2
13	4-Way Apex Connector		4
14	4-way Cross Rail Clamp		16
15	3-way Cross Rail Clamp		8
16	15" Anchor		4
17	Cable - 1'lengths		4
18	Cable Clamp		4
19	Foot Plate		8
20	Pin		8
21	Split Pin		8
22	M6 x 45 Bolt		12
23	M6 x 40 Bolt		20
24	M6 Washer		32
25	M6 Locknut		32
26	Roof Tarpaulin(main cover)		1
27	Door Panel with zipper		1
28	Back Cover Panel		1
29	Ratchet		8

# ASSEMBLY



**WARNING: DO NOT PLACE THE PRODUCT UNDER TREES FROM WHICH HARD FRUIT SUCH AS APPLES, WALNUTS OR HEAVY PINE CONES, ETC., MAY FALL. KEEP CHILDREN AWAY DURING ASSEMBLY. THIS PRODUCT CONTAINS SMALL PARTS WHICH CAN BE SWALLOWED BY CHILDREN. DO NOT ATTEMPT TO ASSEMBLE THE PRODUCT IF ANY PARTS ARE MISSING.**

**WARNING: AT LEAST 3 PEOPLE ARE NEEDED TO COMPLETE THE ASSEMBLY AS SOME OF THE STEPS REQUIRE HEAVY LIFTING.**

**WARNING: DO NOT LEAVE THE GARAGE UNATTENDED DURING ASSEMBLY IN CASE PERSONAL INJURY OR DAMAGE MAY OCCUR.**

1. Place all parts in a clear area and arrange them on the ground. Check for completeness and for any transport damage.
2. Remove all packaging materials and place them back in the box. Do not dispose of the packaging materials until assembly is complete.

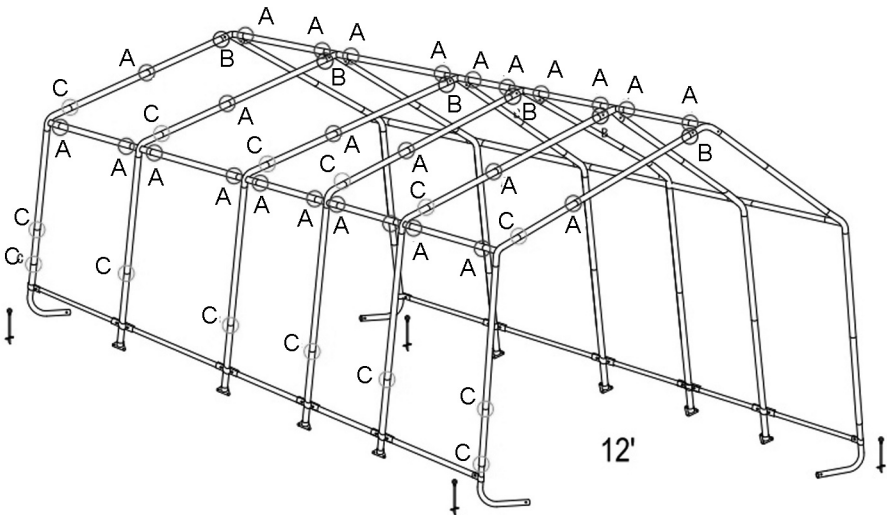

3. The diagram above shows which type of connection is required for each part of the frame assembly.
  - Joint A is a spring button connection
  - Joint B is connected with bolt and nut
  - Joint C is a simple push-fit

## STEP 1: PREPARING THE ROOF PARTS

Select a suitable location for the garage. The layout of the roof parts is shown in diagram B.

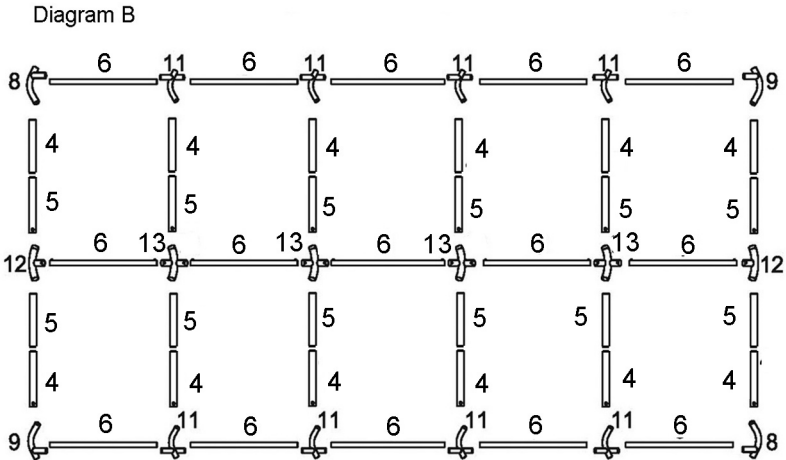

Note the differences between the connectors shown in Diagram C. (connectors are also individually numbered).

Note: When installed, the welded socket for the cross rail must be below the bend.

Parts #8, #9 & #11 are side shoulder connectors.

Parts #12 & #13 are top apex connectors.

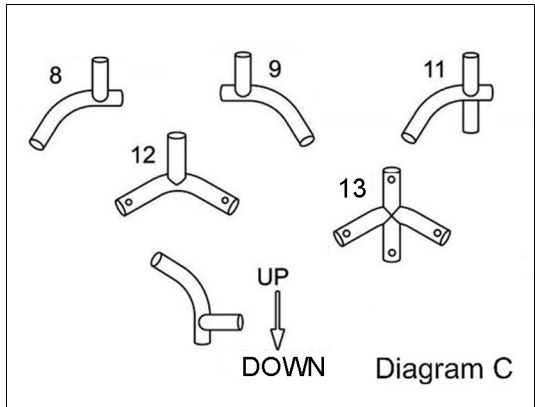

## STEP 2: ASSEMBLING THE ROOF

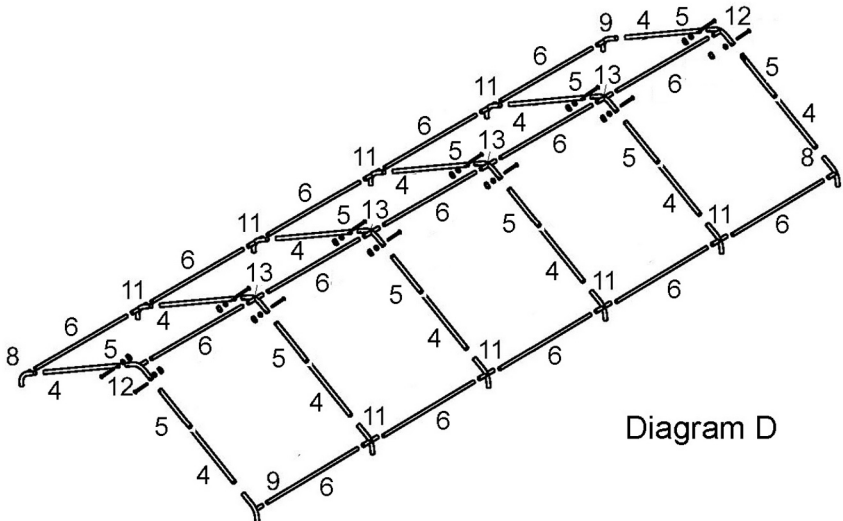
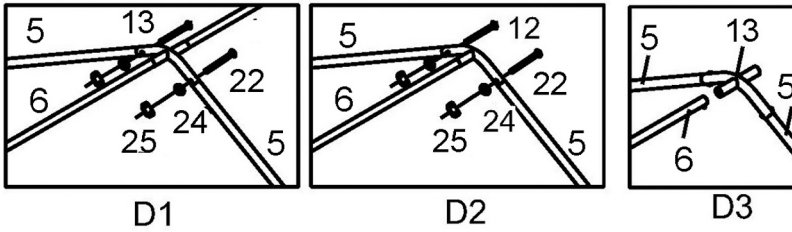

1. Assemble the roof frame by connecting the parts layout above.
2. Connect one end of Part #5 with Part #4 using the spring button.
3. Connect the other end of Part #5 with Parts #12 & #13 (See Diagram D1 & D2) by the fittings #22, #24 & #25.
  - There are spring buttons on both end of Part #6. Make sure the button pops up when connecting with Parts #8, #9 & #11.
4. Use a rubber or wooden mallet if needed to ensure all tubes are fully inserted.



### STEP 3: ATTACHING THE LEGS

1. There are 12 legs for the whole structure.
2. Follow Drawing E1. Connect the tubes #1, #3 & #10 to create the 4 corner legs.
3. Connect tubes #1 & #2 to create the 8 center legs.

Diagram E

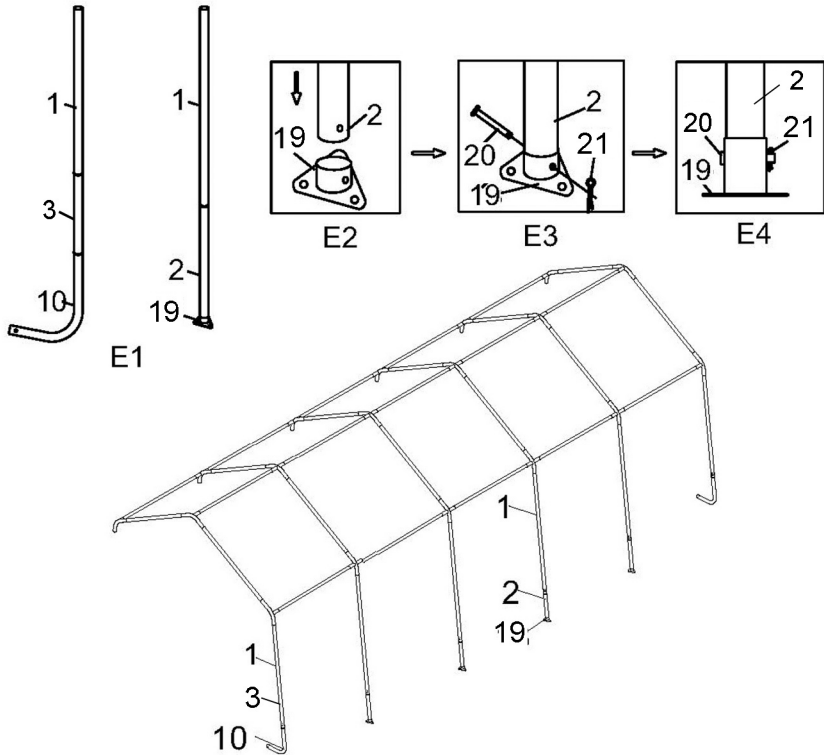

4. Insert the Center Legs into the Foot Plate (#19). Align the holes in the pole and foot plate, push the Pin (#20) through all the holes, insert the split pin (#21) and spread the tongues of the split pin with a flat screwdriver to secure this connection. (See Diagrams E2, E3 & E4.
5. Insert the centre legs and corner legs into the side connectors as in Diagram E4.
6. Repeat to assemble the other side (as shown in Diagram E).

## STEP 4: SQUARE AND ANCHOR THE FRAME



**WARNING: SERIOUS INJURY TO PERSONS OR PROPERTY COULD RESULT IF THE GARAGE IS NOT SECURELY ANCHORED, WITH EITHER THE GROUND ANCHORS SUPPLIED OR IF SITED ON CONCRETE OR TARMAC USE SUITABLE SUBSTANTIAL GROUND ANCHOR BOLTS.**

1. Check the measurements of the frame are 12' at both the front and back corners, as well as across the center.

Diagram F

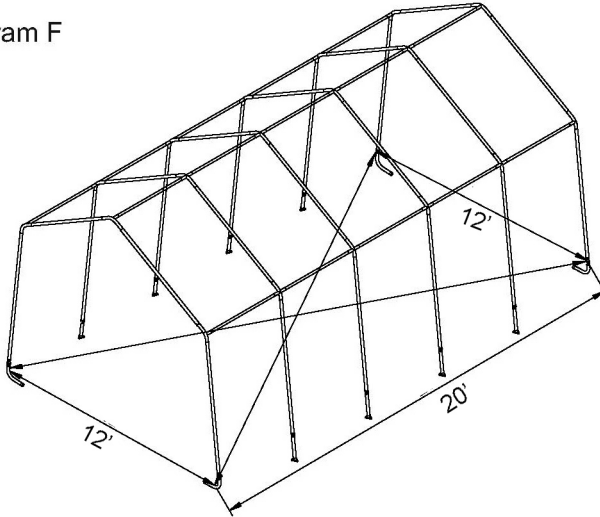

2. Take a diagonal measurement as shown in Diagram F. When these two measures are equal the frame is square. Adjust the frame until they are equal to within 1".

3. Check the width measurement again to ensure all widths are equal at 12'.

4. Next, install the anchors (Parts #16, #17 & #18) at the 4 corner bent legs by screwing the removable anchor (#16) into the ground on the inside of the frame.

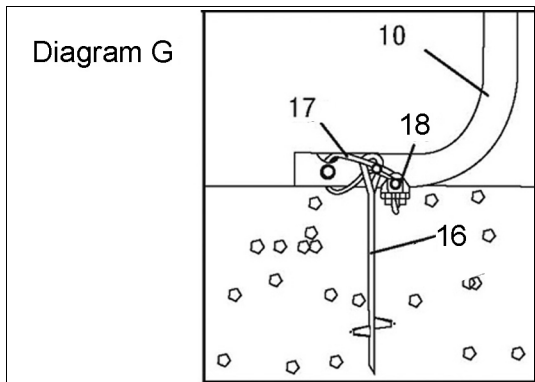

5. Secure with cable (#17) and cable clamp (#18) (as shown in Diagram G).

- **Ensure the clamps are gripping the cables securely.**

## STEP 5: INSTALLING THE FRONT AND BACK COVERS

The front cover has a zippered door to allow entry to the garage. Be sure to locate this cover at the desired end and ensure the zipper is in the closed position while assembling. The back cover is a solid piece of fabric. Both the covers are installed in the same manner.

Diagram H

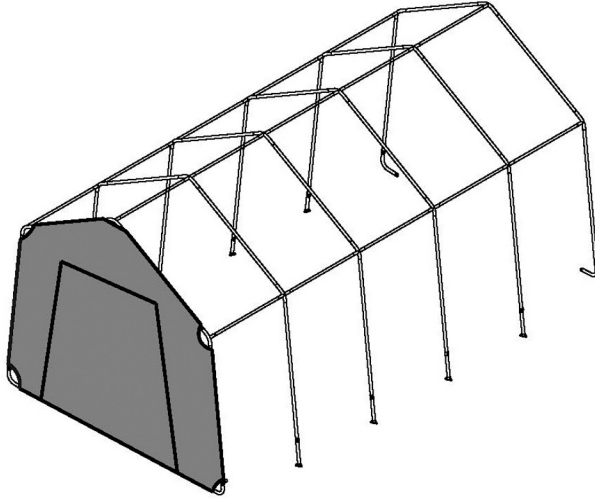
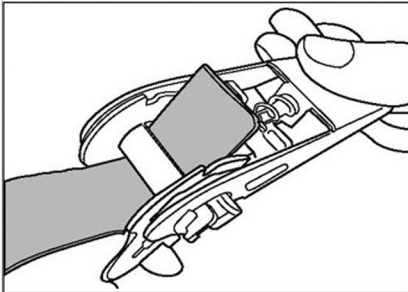
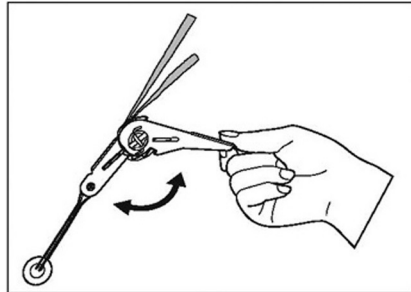

Diagram I



I-1



I-2

1. Thread the strap through the spindle of the ratchet to make sure the strap will stay in the sleeve when assembled. Raise and lower the handle two or three times to wind the strap onto the spindle as shown in diagrams I-1 & I-2.
2. Begin with the front cover and first locate the webbed strap that runs around the perimeter of the cover.
  - The webbing is exposed at the apex, the shoulders and feet of the cover.

- Using a rubber mallet, disconnect the shoulder tube (#6) from the connector (#8 or #9) located between the leg and the roof tubes. as in diagram J.

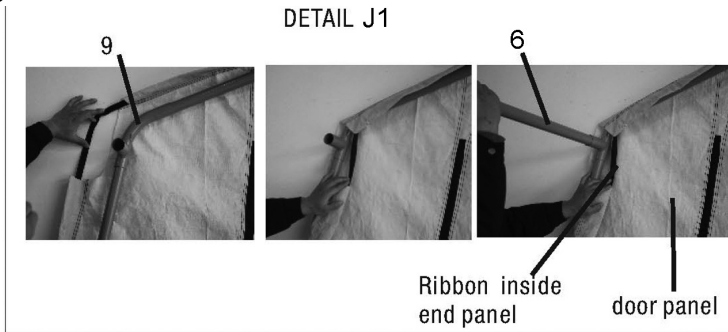
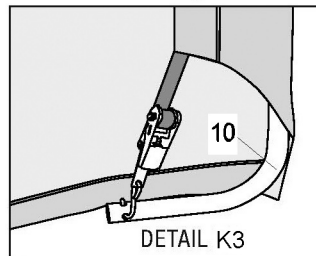
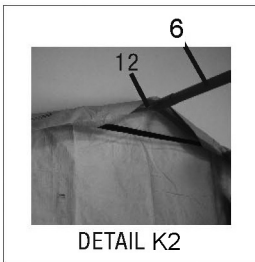
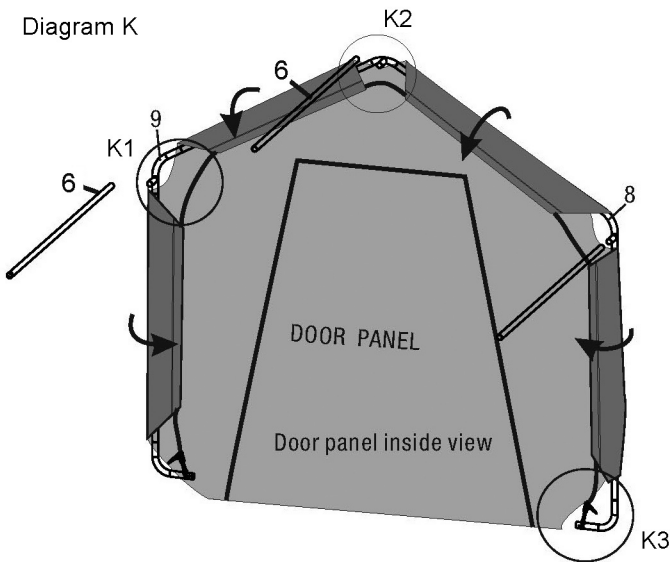

Diagram K



- Slip the webbing strap between tube (#6) and the connector as shown in diagram J and re-connect the tubes.
- Repeat this step for the opposite shoulder.

6. Move to the apex of the garage using a stool or ladder and, using a rubber mallet, disconnect the apex tube (#6) from the connector (#12). Slip the webbed belt between the tubes as in diagram K2 and reconnect.
7. While one person remains on the steps and standing at the apex of the garage the other person inserts the S-hook of the ratchets into both sides of the corner legs (K3).
8. The person standing at the apex assists by ensuring the tarpaulin is partially folded over the tubes of the end frame and inside or towards the interior of the garage.
9. The other person makes sure the door panel is flat and then tightens the ratchets as in Diagram K3 until the door panel is in tension.
10. Repeat the above steps for the other side of the back panel assembly.
11. Do not overtighten the ratchets at this time.

## STEP 6: INSTALLING THE MAIN COVER

1. Lay the cover on the ground next to the frame with the inside of the cover (the side with the pockets) facing down and the strap on the front and rear of the frame.
2. Tie a rope to the eyelets on the cover, one each side. Another rope in the middle helps if another person is available.

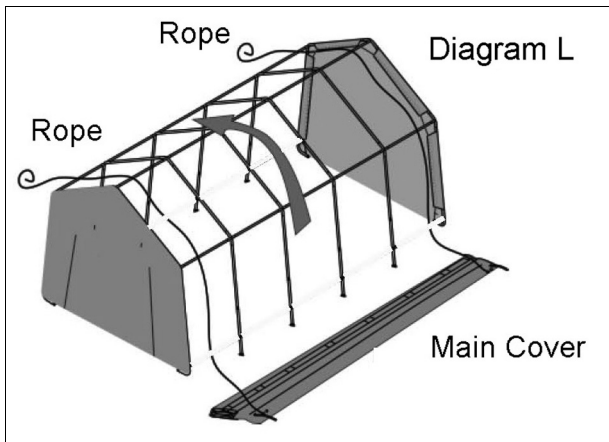

3. Pull the cover over the frame using the rope as in Diagram L, making sure to centre the cover on the frame. There should be an equal overhang on each corner.
4. Assemble the ratchet tie-down (#29) to the strap ends on the four corners of the cover, one to each corner. Ratchet a few times to tighten the strap to the ratchet spool.

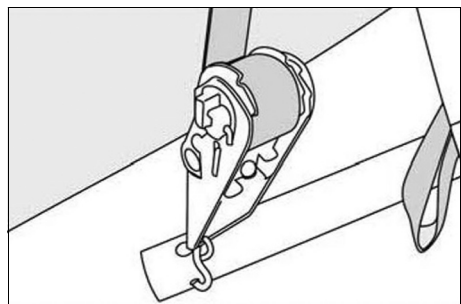

5. Insert the hook the ratchet into the hole on the bent corner leg. Wind the ratchet so that the webbing overlaps itself.
6. Slide the bottom cross rails through the fabric pockets at each leg and re-attach with clamps at each leg. Repeat this on the other side. Repeat this on the other side. Push down on the cover rails to tighten the cover before tightening all bolts completely

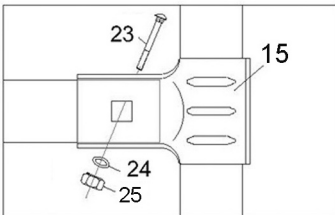
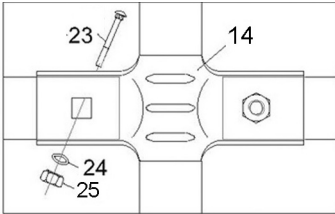

7. When the cover rails are all secured, proceed to the four corners and tighten the end covers to the end frames using the ratchet action.

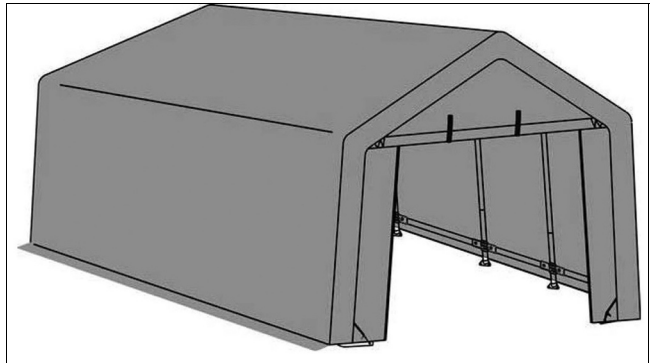

**NOTE:** Over-tightening can cause damage to straps and/or the anchor point. Do not over-tighten!

8. Check periodically (two to three times in the first week and tighten ratchet tie-downs and all hardware as needed. Monthly inspection is recommended throughout usage.



**WARNING: IF POSITIONING THE SHED IN A WINDY LOCATION ALWAYS ENSURE THE FRONT DOOR IS KEPT FULLY CLOSED TO PREVENT WIND LIFTING THE SHED FROM INSIDE.**

## DISASSEMBLY

When disassembling the garage depress the spring-loaded bar to disengage the ratchet and open the ratchet handle completely to allow the webbing strap to pull through.

PLEASE RE-READ ALL WARNINGS CONTAINED ON PAGE 2/3 OF THESE INSTRUCTIONS. SAVE THESE INSTRUCTIONS FOR FUTURE USE.

To dismantle, execute all instructions in reverse order. Store your garage in a cool, dry location between seasons to prolong the usable life of all components.

Components are not equally durable and will require replacement over time at differing intervals.

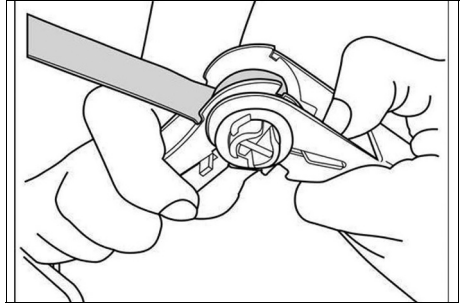

## ADDITIONAL ANCHORING

Please note that when the instant garage or shed is to be sited on soft ground an additional, or alternative method of anchoring may be required.

This can take the form of an additional Auger Securing Set GA1 (already supplied with Clarke instant garages), which can add greater security for exposed, windy locations.

Alternatively the Easy Hook Anchoring System GHA2, can be used to provide greater security on soft ground. Available from your Clarke dealer.



**WARNING: SERIOUS INJURY TO PERSONS OR PROPERTY COULD RESULT IF THE GARAGE IS NOT SECURELY ANCHORED.**

# A SELECTION FROM THE VAST RANGE OF

# Clarke®

## QUALITY PRODUCTS



### AIR COMPRESSORS

From DIY to industrial, Plus air tools, spray guns and accessories.

### GENERATORS

Prime duty or emergency standby for business, home and leisure.

### POWER WASHERS

Hot and cold, electric and engine driven - we have what you need

### WELDERS

Mig, Arc, Tig and Spot.  
From DIY to auto/industrial.

### METALWORKING

Drills, grinders and saws for DIY and professional use.

### WOODWORKING

Saws, sanders, lathes, mortisers and dust extraction.

### HYDRAULICS

Cranes, body repair kits, transmission jacks for all types of workshop use.

### WATER PUMPS

Submersible, electric and engine driven for DIY, agriculture and industry.

### POWER TOOLS

Angle grinders, cordless drill sets, saws and sanders.

### STARTERS/CHARGERS

All sizes for car and commercial use.



## PARTS & SERVICE: 0208 988 7400

**Parts Enquiries**  
[Parts@clarkeinternational.com](mailto:Parts@clarkeinternational.com)

**Servicing & Technical Enquiries**  
[Service@clarkeinternational.com](mailto:Service@clarkeinternational.com)

SALES: UK 01992 565333 or Export 00 44 (0)1992 565335

**Clarke** INTERNATIONAL Hemnall Street, Epping, Essex CM16 4LG  
[www.clarkeinternational.com](http://www.clarkeinternational.com)